



LeMatic
Cooler to the door

Soft Product Hinge/Web Slicer

GU10/GU10W

FEATURES

- Hinge or web slicing capability
- Exclusive spinner/separators unit provides superior slicing of cluster hot dog rolls
- Floating head pressure design produces a consistent quality slice
- Completely adjustable for slicing height, slicing depth and top conveyor pressure
- Can be mounted on existing LeMatic conveyor frame or revised for customer-supplied frame
- Standard power-lift head raises out of position to bypass unsliced product
- Design emphasizes safety and reliability, straight forward operation and complete accessibility for maintenance and sanitation



*Shown with optional
head-mounted guides*

Soft Product Hinge/Web Slicer

GU10/GU10W

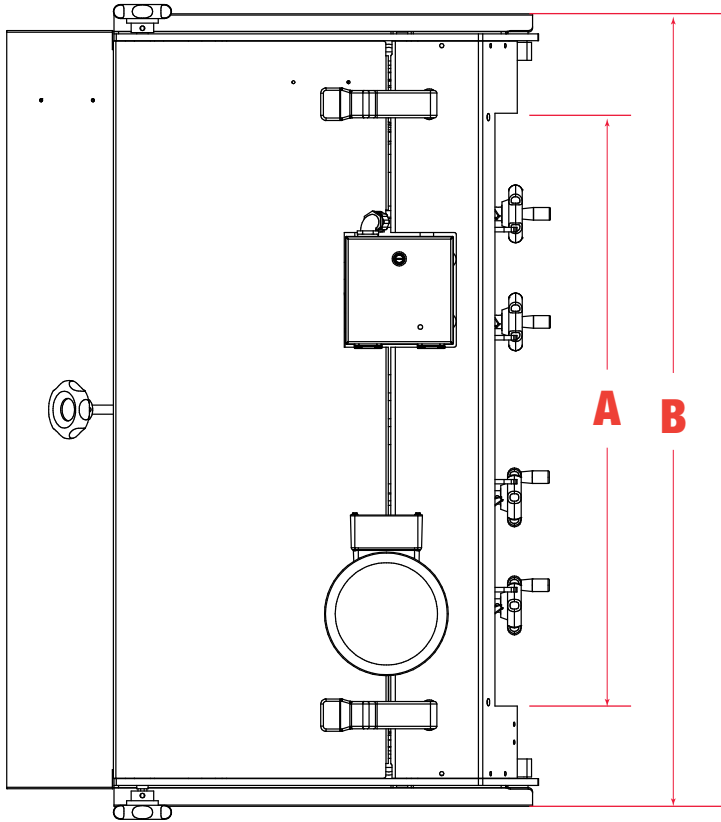

Model	Belt Width "A" In. [mm]	Frame Width "B" In. [mm]	# of Knife Spindles	Cluster Spinners
GU10-5-0	26 [660]	34½ [876]	5	0
GU10W-5-2	34 [864]	42 [1067]	5	2
GU-10-7-0	26 [660]	34.5 [876]	7	0
GU10W-7-2	34 [864]	42 [1067]	7	2

GENERAL SPECIFICATIONS:

- Production Rate: Maximum of 800 pcs./min. based on 4" round roll
- Electrical: All standard voltages
- Control Voltage: 24VDC, other voltages available
- Air Requirements: None
- Slicer Head Drive: 2 HP w/Brake

OPTIONS:

- Five or seven spindles
- UL, CUL/CSA, CE compliance
- Slicer head for a 26" or 34" wide belt conveyor
- Wash-down construction
- Exclusive spinner/separator unit for slicing cluster hot dog rolls
- Exclusive "Floating Top Conveyor" (FTC), designed especially for hearth or delicate type products, compensates for product height variations

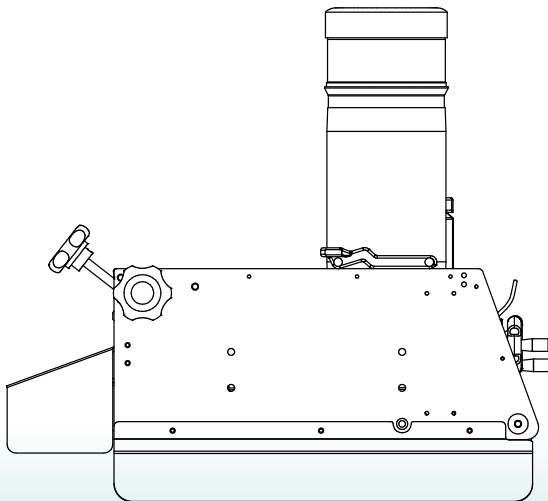

LeMatic
Cooler to the door