



LeMatic

AUTOMATION FOR BAKERY

Pattern Former

P7

LeMatic takes another step towards total automation of the packaging line with the introduction of the LeMatic P7 Pattern Former and Loader. The P7 has been designed with industry-leading capacity, up to 70 packages per minute. Linear motors increase efficiency and flexibility while maximizing speed. LeMatic's all-in-one approach combines pattern forming and tray loading, reducing overall maintenance, while saving space and reducing labor.



FEATURES

- **Heavy-duty stainless steel frame** - LeMatic continues its "Built for Bakery" industry standard, using fully-welded 4" square tubing in an improved sanitary design.
- **High-speed linear motors** - Capable of fast accelerations and high speeds while providing unmatched precision and accuracy. Provides consistent and precise product placement.
- **Auto iNet integrated** - State-of-the-art components along with LeMatic Auto iNet, provide live feedback, operational reporting, remote support and operator & maintenance training.
- **Versatile design** - New recipes/patterns can easily be designed at the HMI without factory assistance.
- **Quick-change tooling** - minimizes changeover time between products.

Pattern Former

P7

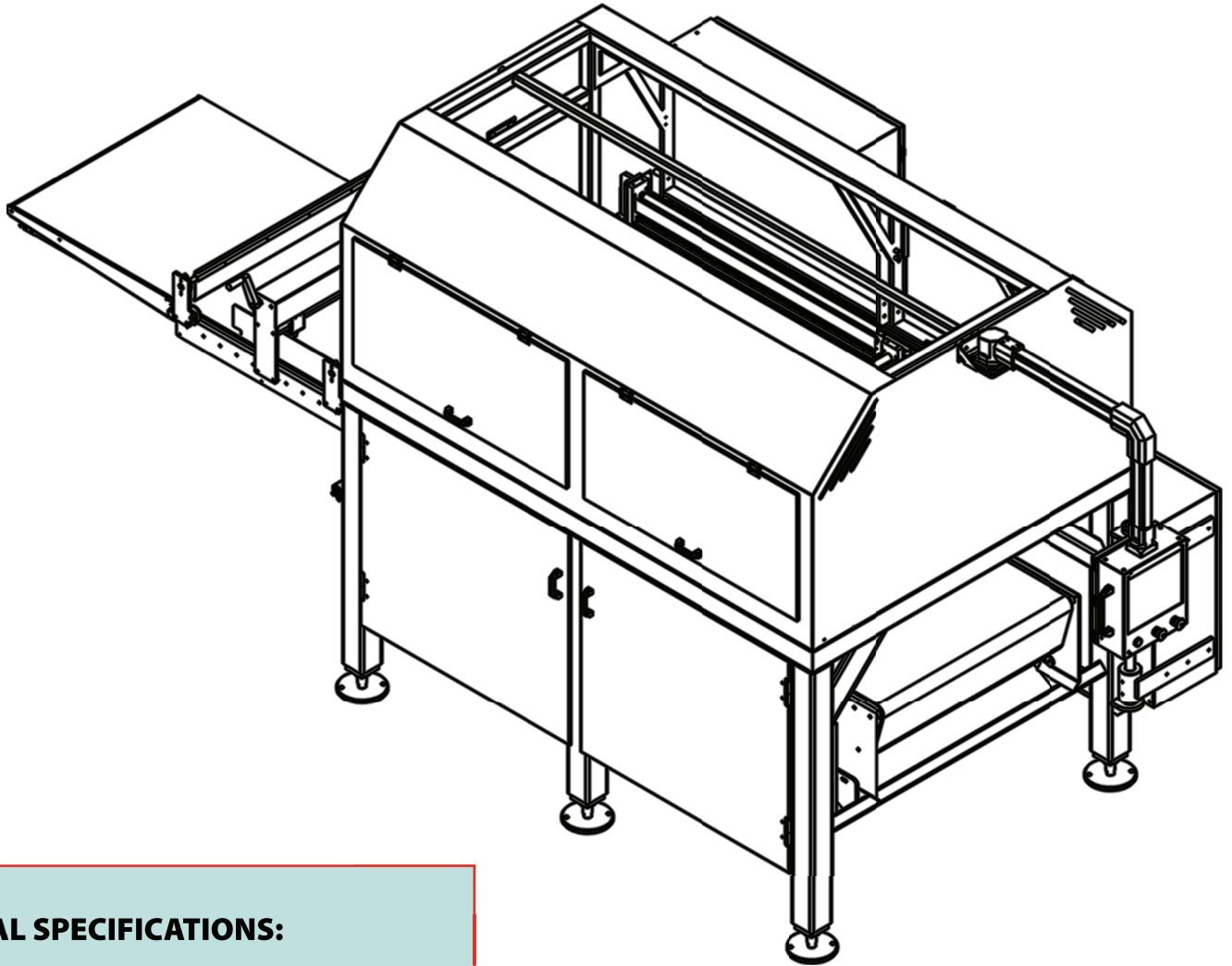

GENERAL SPECIFICATIONS:

- 480V-3Ph-60Hz standard, other available
- Approximately 3 cfm @ 90 PSI @ 70 ppm

Optional AutoEye technology utilizes a high-resolution camera. The optical recognition identifies the position of incoming packages. This allows for proper orientation prior to pattern forming, with the ability to correct mis-aligned or rotated packages.



LeMatic

AUTOMATION FOR BAKERY

6/22