



LeMatic
Cooler to the door

2-Position Slicing System

CONFIGURED TO YOUR SPECIFICATIONS

LeMatic Slicers have been the industry benchmark for nearly 50 years. Our standard 2-Position Slicing System can be configured to slice a wide variety of fresh, soft and artisan-style bun and roll products.

FEATURES:

- Rugged, reliable, sanitary, flexible and safe design
- Heavy-duty stainless steel frame and panel construction
- All controls mounted to slicer frame
- Accommodates one or two LeMatic band, hinge, web or top slicing heads with powered head lifts
- Adjustable guides form multiple lanes, depending on slicing needs
- All slicer adjustments are made by an operator without tools
- Supports both hand-feed and conveyor-feed applications
- Wide (34" belt) and narrow (26" w belt) standard models



Product slide with adjustable guide for conveyor feed applications

2-Position Slicing System

Configured to Your Specifications

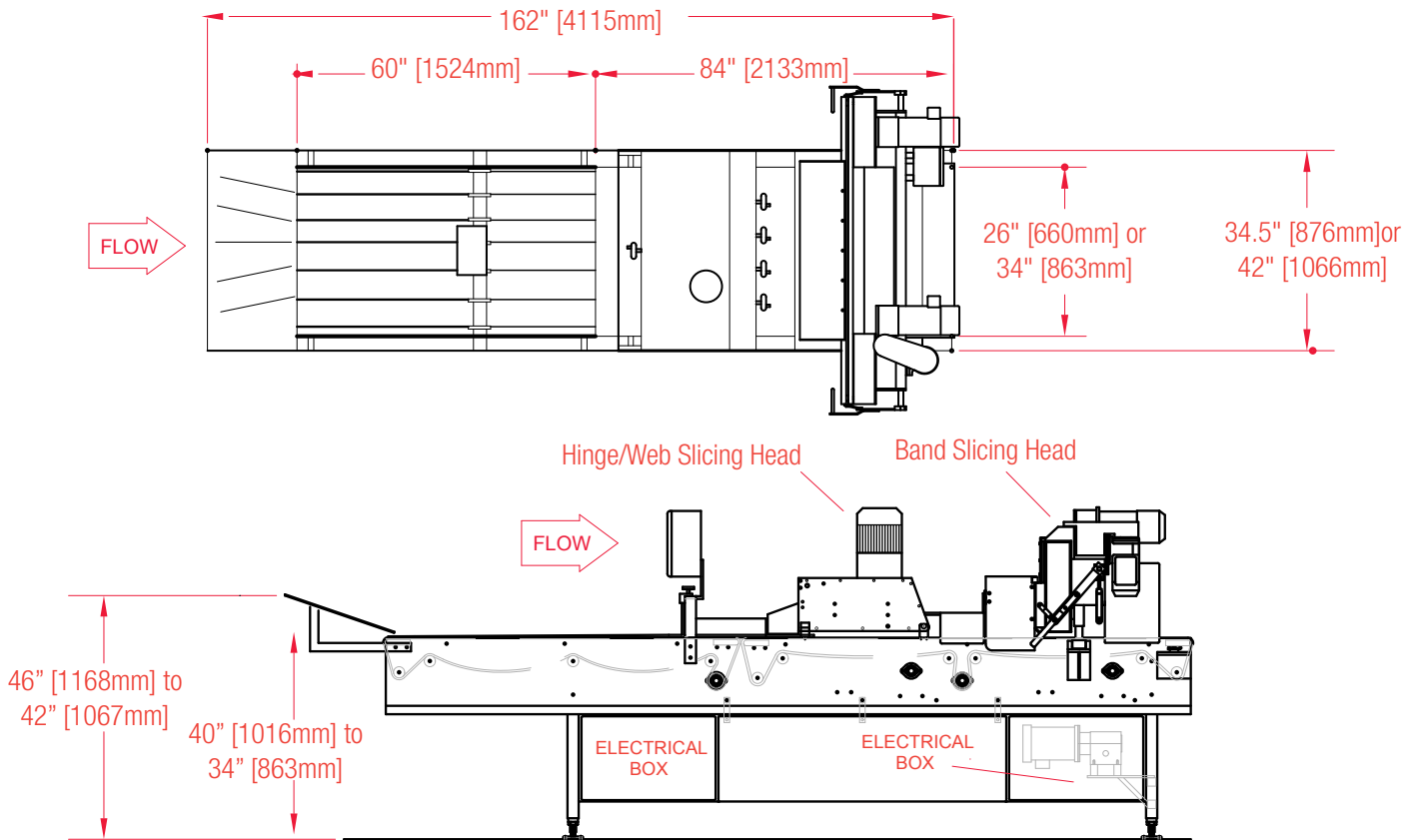

GENERAL SPECIFICATIONS:

- Speed: Variable
- Electrical: All standard voltages
- Control Voltage: 24VDC
- Air Requirements: Slicer dependent

SLICERS AVAILABLE:

- Band slicing, single or double-through slice
- Hinge/Web Slicing
- Hearth Roll Slicing
- Top Slicing

OPTIONS:

- Additional lane guides
- Casters and floor brakes
- UL, CUL/CSA, CE compliance
- Additional slicing modules
- Full wash-down/USDA construction
- Custom lengths, widths and elevations



LeMatic
Cooler to the door