



**LeMatic**  
*Cooler to the door*

# TS-8 Top Slicer

**MULTIPLE VARIATIONS AVAILABLE**



*Shown:  
Model TS-8*

## **FEATURES**

- Vertical Top Slicing
- Adjustable slicing depth
- Can be mounted on existing LeMatic conveyor frame or engineered to fit customer's existing frame
- Design emphasizes safety and reliability, straight forward operation and complete accessibility for maintenance and sanitation
- Standard Power Lift raises slicing head out of position to bypass unsliced product
- Optional Manual Lift available



*Blades are factory preset based on product requirements*

*Pictured: Eight blade configuration with Optional Head Mounted Guides, for a cluster 4 Hot Dog application (TS-8W)*

# TS-8 Top Slicer

## Multiple Variations Available

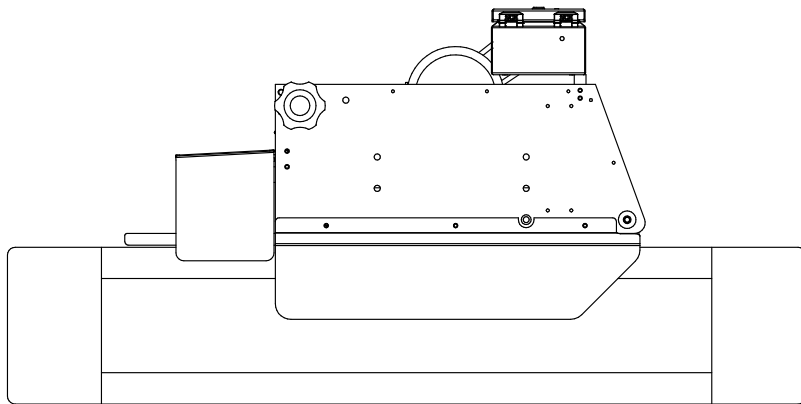
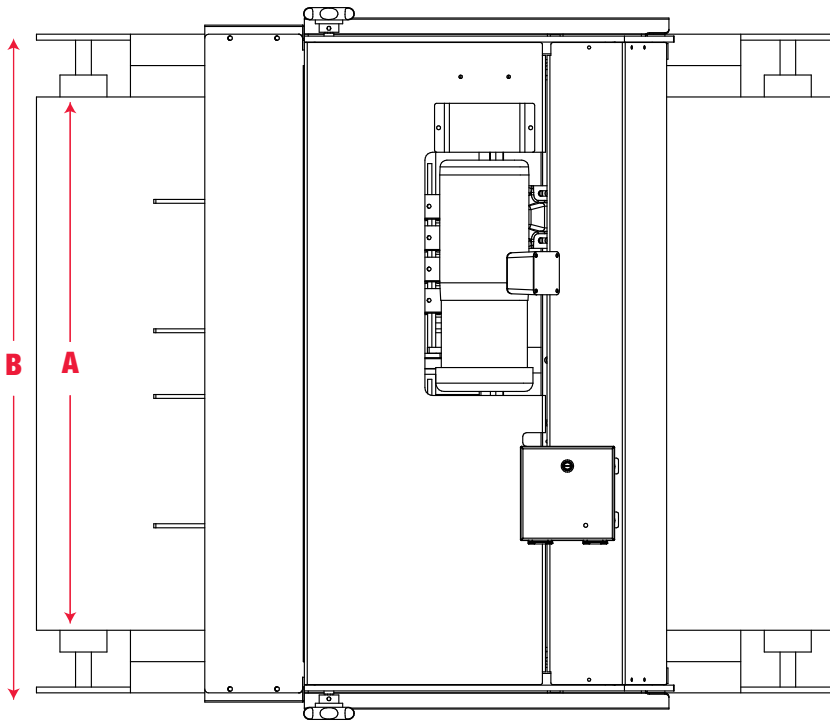

Model	Belt Width "A"	Frame Width "B"	# of Vertical Blades
	In. [mm]	In. [mm]	--
TS-2	26 [660]	34½ [876]	2
TS-6	26 [660]	34½ [876]	6
TS-8	26 [660]	34½ [876]	8
TS-6W	34 [864]	42 [1067]	6
TS-8W	34 [864]	42 [1067]	8
TS-10W	34 [864]	42 [1067]	10
TS-12W	34 [864]	42 [1067]	12
TS-15W	34 [864]	42 [1067]	15
TS-17W	34 [864]	42 [1067]	17
TS-21W	34 [864]	42 [1067]	21

Wash Down Construction models are available

### GENERAL SPECIFICATIONS:

- Production Rate: Up to 60,000 pieces per hour
- Electrical: All standard voltages
- Control Voltage: 24VDC, other voltages available
- Air Requirements: None
- Slicer Head Drive: 1 HP w/Brake

### OPTIONS:

- Multiple Vertical Blade Configurations
- UL, CUL/CSA, CE compliance
- Slicer for a 26" or 34" wide belt conveyor
- Cluster and Individual Slicing Capabilities
- Optional Head Mounted Guides

