



**LeMatic**  
*Cooler to the door*

# Dry Bun Pan Cleaner

**BM100303, BM100305, BM100307, BM100309**

LeMatic's dependable Bun Pan Cleaning Systems will stand up to the rigors of your high-production bakery operation. Innovative design emphasizes safety and reliability, straight-forward operation and ease of maintenance.

## FEATURES:

- Two stage brushing action aggressively loosens debris from pan top and sides
- The dual-action, counter-balanced air/vacuum head removes debris from the pan
- Regenerative blower and debris collection vacuum system included
- Flexible design allows mounting on customers' conveyor, optional LeMatic floor standing conveyor (level or inclined)
- Gear motor driven power lift eliminates the need for compressed air lines and cylinder replacement.



*Included vacuum system not shown.  
Pictured with optional LeMatic floor-standing conveyor.*

# Dry Bun Pan Cleaner



**BM100303, BM100305, BM100307, BM100309**

## Pan Cleaner & Conveyor

### PAN CLEANER DIMENSIONS:

	BM100303	BM100305	BM100307	BM100309
<b>A</b> Conveyor Belt Width:	22" (559mm)	26" (660mm)	36" (914mm)	40" (1016mm)
<b>B</b> Brush Width:	24" (610mm)	30" (762mm)	38" (965mm)	40" (1016mm)
<b>C</b> Cabinet Width:	34" (864mm)	40" (1016mm)	46" (1168mm)	50" (1270mm)
<b>D</b> Inside Frame Width:	34" (864mm)	40" (1016mm)	46" (1168mm)	52" (1321mm)
<b>E</b> Outside Frame Width:	41" (1041mm)	47" (1194mm)	53" (1346mm)	59" (1498mm)

### OPTIONS:

- UL, CUL/CSA, CE compliance
- Metric requirements
- Wash down construction
- Variable speed brushes

### CONVEYOR OPTIONS:

- Pan bottom cleaning assembly
- Incline or specialty conveyor designs
- Floor standing support
- Flighted conveyor for aluminium pans

### GENERAL SPECIFICATIONS:

Maximum Conveyor Speed:	100ft./min [30.5M/min]
Electrical Controls:	208-230-460 Volt 60 Hz 3 Ph (Other voltages available)
Control Voltage:	24VDC (Other voltages available)
Air Requirements:	1" NPT(min. 3/4" NPT) air line w/ filter and regulator 18 CFM @ 90psi
Connected Load:	15 to 19KVA

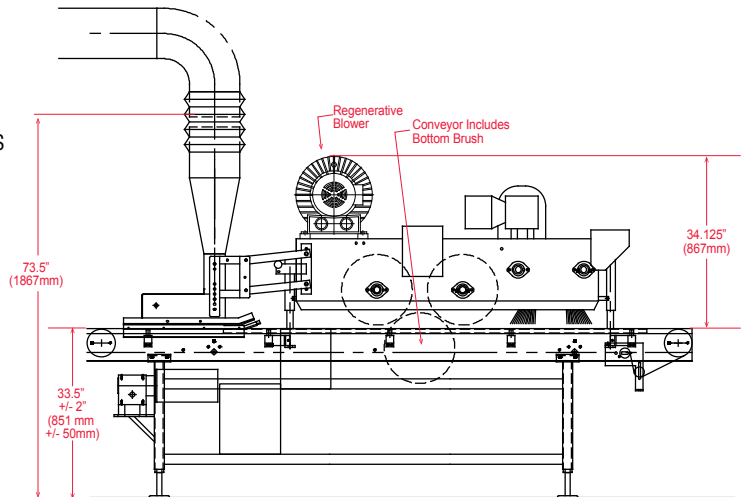
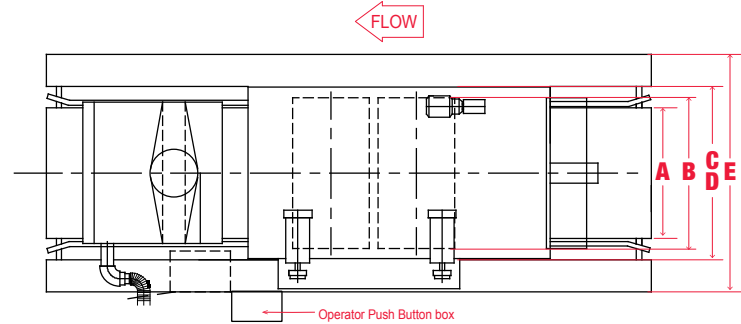

## Pan Cleaner Vacuum System

The vacuum system is included with the Dry Bun Pan Cleaner and configured to your requirements. Do you want to talk about this? What more can we say? Sanitary? Recycle those yummy crumbs?

